

Engine	Xinchai A490BPG / 2.54 L	Yanmar 4TNE98-BQFLC / 3.318 L
Fuel Type	Diesel	Diesel
Capacity @ 500 mm LC	3,500 kg	3,500 kg

CLG2035H

DIESEL
PNEUMATIC TIRE FORKLIFTS



TOUGH WORLD. TOUGH EQUIPMENT.

CLG2035H SPECIFICATIONS >>>

General	Model	1			2035H	2035H
	Power Type	2			Diesel	Diesel Tier III
	Base Capacity	3	@ rated load center	kg	3,500	3,500
	Load Center	4		mm	500	500
Weights	Service Weight	5	unloaded	kg	4,750	4,750
	Axle Load	6	loaded / unloaded, front	kg	7,275 / 1,700	7,275 / 1,700
		7	loaded / unloaded, rear	kg	975 / 3,050	975 / 3,050
Tires	Tire Type	8			Pneumatic	Pneumatic
	Wheels	9	front / rear		2 / 2	2 / 2
	Wheelbase	10		mm	1,700	1,700
	Tire Size	11	front		28x9-15-12PR	28x9-15-12PR
		12	rear		6.50-10-10PR	6.50-10-10PR
13	front / rear			1,000 / 980	1,000 / 980	
Mast	Max. Fork Height	14	with std 2-stage mast	mm	3,000	3,000
	Freelift	15	with std 2-stage mast	mm	130	130
	Height, Upright Lowered	16	with std 2-stage mast	mm	2,120	2,120
	Height, Upright Extended	17	with std 2-stage mast	mm	4,278	4,278
	Mast Tilt, Fwd/Back	18	with std 2-stage mast	deg	6° / 10°	6° / 10°
	Carriage	19	width	mm	1,100	1,100
	Fork Spread	20	minimum / maximum	mm	272 / 1,072	272 / 1,072
	Fork Dimensions	21	T x W x L	mm	50 x 122 x 1,070	50 x 122 x 1,070
	Chassis	Length to Fork Face	22	with std 2-stage mast	mm	2,730
Overall Width		23		mm	1,240	1,240
Overhead Guard Height		24		mm	2,170	2,170
Turning Radius		25	minimum outside	mm	2,450	2,450
Fork Overhang		26	with std 2-stage mast	mm	480	480
Right Angle Stack		27	add load length and clearance	mm	4,195	4,195
Ground Clearance		28	minimum loaded	mm	120	120
		29	center of wheelbase	mm	135	135
Performance		Travel Speed	30	loaded / unloaded	km/h	19 / 20
	Lift Speed	31	loaded / unloaded	m/s	0.42 / 0.52	0.42 / 0.52
	Lower Speed	32	loaded / unloaded	m/s	0.6 / 0.4	0.6 / 0.4
	Max. Drawbar Pull	33	loaded	kg	2,070	2,225
	Max. Gradeability	34	loaded / unloaded	%	18 / 20	18 / 20
Systems	Brakes	35	service		Foot / Hyd	Foot / Hyd
		36	parking		Hand / Mech	Hand / Mech
		37	manufacturer		Xinchai	Yanmar
	Engine	38	model		A490BPG	4TNE98-BQFLC
		39	emission compliance		China Tier II	EPA / Euro Tier III
		40	cylinders		4	4
		41	displacement	liter	2.54	3.318
		42	rated power	kW/rpm	36.8 / 2,650	42.1 / 2,300
		43	max. torque	N • m/rpm	148 / 1,900	196.3 / 1,700

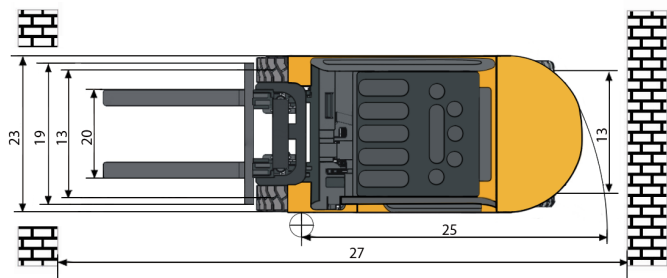
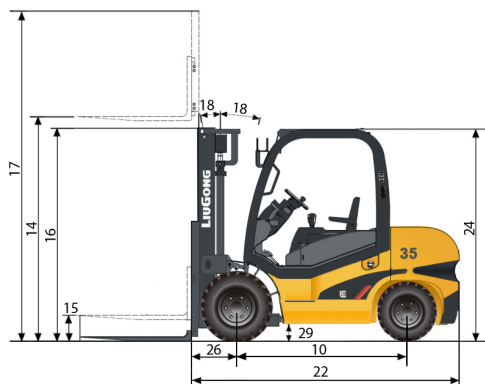

Guangxi Liugong Machinery Co., Ltd.

No. 1 Liutai Road, Liuzhou, Guangxi 545007, PR China
 T: +86 772 3886124 E: overseas@liugong.com
 www.liugong.com

06/2014 Designed by Liugong

Specifications and designs are subject to change without notice. Machines shown may include optional equipment.