

A yellow and grey Dieci Zeus 35.10 skid steer loader is shown from a low-angle perspective. The machine is parked on a light-colored paved surface under a clear blue sky. The loader's boom is visible in the upper left. The side of the machine features the Dieci logo and the model name Zeus 35.10. The tires are large, treaded, and mounted on yellow rims. The overall image is a promotional photograph for the machine.

DIECI
AUSTRALIA

ZEUS | 35.10



ABSOLUTE COMFORT: ITALIAN DESIGN AND STYLE

Dieci telehandlers have always been a combination of **comfort** and **functionality** which makes us stand out all over the world.

Reliability & Productivity

Ideal for work environments where there is a need to handle large volumes and reduce work cycles. Maintenance is straightforward, with durable components and materials designed to last.

Advanced Telescopic Boom

Made of high resistance steel, while load sensing and flow sharing distributors allow for more simultaneous movements during operation.

Not Only Power

The Zeus responds to controls in a fluid way, with precision and promptness, thus guaranteeing exceptional work comfort in complete safety.

Perfect Climate

Equipped with an integrated electric driver's window, standard heater and a semi-automatic air conditioning system with six outlet vents, this setup allows perfect air circulation inside the cabin for maximum operator comfort.

Maximum Safety

The ROPS-FOPS approved cab is designed with a safety cell to provide maximum safety to the operator at all times. Dieci telehandlers comply with AS1418.19 / 10896.1.

Deadman sensor, combined with operator presence sensor in the seat, prevents accidental operation.

The Load Limiter Device analyses vehicle stability in real time and inhibits any aggravating movements when the pre-set safety limits are reached.

ZEUS POWER & AGILITY FOR MAXIMUM EFFICIENCY

The needs on construction sites are changing. Management costs must be reduced and machine productivity continuously improved. Dieci meets the demands of customers with more versatile, more robust and more reliable machines that are easy to drive and operate.

The **Zeus 35.10** features the perfect balance between power and agility. It is designed to handle heavy loads in confined spaces, making it ideal for various demanding applications.

Great power, excellent handling, precision movement control, sound proofing for absolute comfort, three steering modes including 2WS, 4WS and crab steering, as well as the intelligently designed control layout, makes the Zeus simple, intuitive and comfortable to use.

The Zeus can be fitted with a full range of accessories, making it an **incredibly versatile** machine.



ZEUS 35.10

9.75m

Max Reach

3,500kg

Max Capacity

125hp / 93kW

Nominal Power



4-in-1 Joystick

The boom can be fully operated by the hydraulic control distributor-single joystick with proportional and simultaneous controls which also incorporates FNR, for easier and more practical direction control.

Panoramic Views

The large, curved windows of the cab offer a complete 360° outside view with uninterrupted visibility. Integrated LED worklights allow better visibility at night.

Hydrostatic Transmission

Complete with a servo controlled 2 speed gear box and constantly varying hydrostatic drive, which guarantees top-end speed and low-end torque.

Comfort & Ease of Access

With soundproofing, an adjustable steering wheel (height and depth), storage compartments and various accessories such as the air suspension seat, enable operation in total comfort.

Inching Pedal

An essential control that allows travel speed to momentarily slow down or come to a stop while still offering maximum power to boom functions to increase precision and productivity for delicate operations.

146° Fork Swivelling Angle Rotation

Specially designed to increase the operating arc, which is particularly useful when unloading with the boom raised.

Single Compensation Cylinder

Patented by Dieci - is located inside the lifting ram, ensures that the load on the boom is balanced at all times, thereby improving durability.

130 L/min Hydraulic Flow Rate

Up to 130 l/min hydraulic flow maximises manoeuvrability in all applications.

TECHNICAL DATA

PERFORMANCE

Maximum capacity	3,500 kg
Maximum lifting height	9.75 m
Maximum horizontal extension	6.55 m
Fork swiveling angle	146 °
Pull-out force	5,700 daN
Towing force	7,300 daN
Maximum climb angle	40 %
Unladen weight	8,000 kg
Maximum speed	30 km/h

ENGINE

Brand	FPT
Nominal power	125 hp / 93 kW (@ 2,200 rpm)
Operation	4-stroke / diesel
Injection	Mechanical direct
Number and arrangement of cylinders	4, vertical inline
Displacement	4,485 cm ³
Emission standard	Stage IIIA/Tier 3
Cooling	Liquid
Intake	Turbocharger after-cooler

TRANSMISSION

Type	Hydrostatic transmission with variable displacement pump
Hydraulic motor	Hydrostatic with continuous automatic adjustment
Reversal	Electro-hydraulic
Inching control	With hydraulic pedal for controlled forward movement
Gearbox	Servo-controlled 2-speed

HYDRAULIC SYSTEM

Hydraulic pump type	Gear pump for power steering and movements
Hydraulic pump capacity	130 l/min
Maximum operating pressure	24 MPa (3,481 psi)
Boom hydraulic sockets	With quick couplings
Distributor control	4-in-1 joystick with integrated FNR (with deadman capacitive sensor)
Distributor type	Hydraulic distributor-single joystick with proportional controls

TANK CAPACITIES

Hydraulic tank	140 l
Diesel tank	160 l

DIFFERENTIAL AXLES

Steering axles	2 steering, with 4 epicycloidal reduction gears
Type of steering	4 wheels / transversal / 2 wheels
Park brake	Negative actuation with electrical control

TYRES

Size	400/70x20"
------	------------

ZEUS 35.10

DIMENSIONS

A	340 mm
B	1,380 mm
C	2,600 mm
D	970 mm
F	4,060 mm
G	4,950 mm
H	2,310 mm
I	940 mm
L	1,780 mm
M	2,290 mm
O	3,700 mm
P	950 mm
Q	4,000 mm

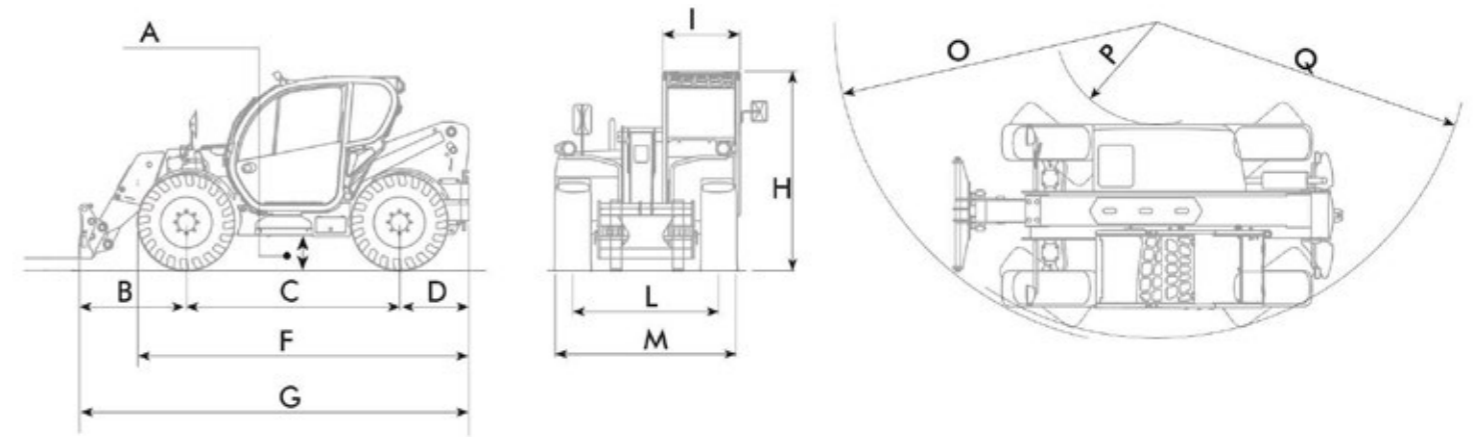

LOAD CHART

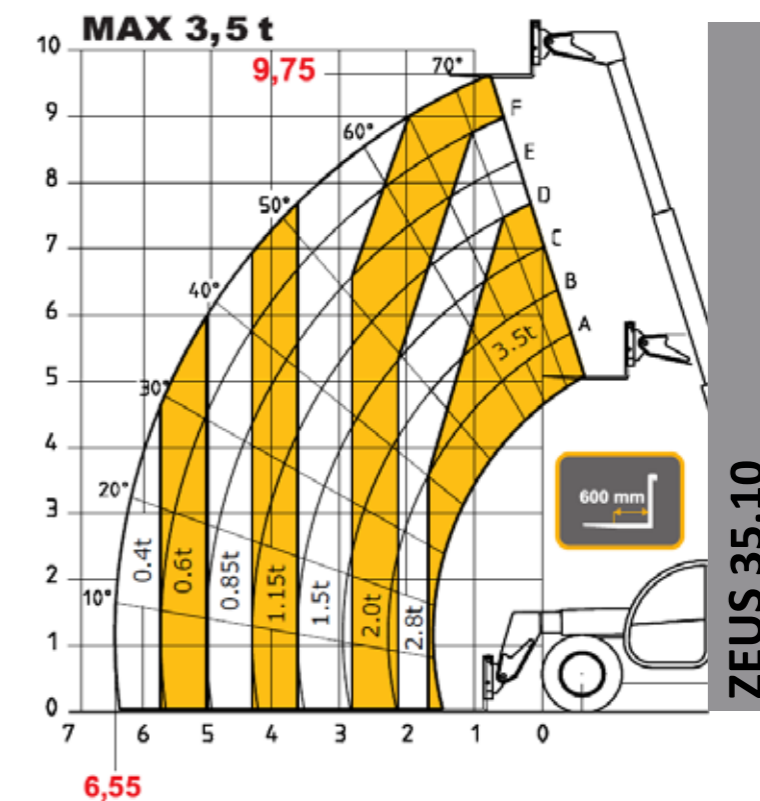



NEW SOUTH WALES

Sydney Branch

1/5 Melito Court,
Prestons, NSW 2170

WESTERN AUSTRALIA

Perth Branch

32 Allott Way,
Maddington, WA 6109

VICTORIA

Melbourne Branch

2/2 Cyanamid Street,
Laverton North, VIC 3026

QUEENSLAND

Brisbane Branch

78-80 Platinum Street,
Crestmead, QLD 4132

Brisbane North Branch

69 Griffin Crescent,
Brendale, QLD 4500



www.dieciaustralia.com.au | ph: 1300 888 479 | sales@dieciaustralia.com.au

Distributed by Dieci Australia

Illustrations and photos show the standard international models and may or may not include optional equipment, accessories, customer installed or modified parts, optional parts and all standard equipment with some differences in colour and features. Machine specifications are subject to change without notice and additional load charts and machine or attachment specifications may be available on request. Please refer to the user and maintenance manuals located on Dieci Australia's website for correct machine and attachment operation.



Printed in Australia

Zeus35.10_0924